

4

3

2

1

NOZZLE SCHEDULE

ITEM	QTY.	ITEM CODE	SIZE	TYPE	CLASS	NOTES
A	4	TF2CURVED	2"	FEMALE NPT	THRD. TANK FLANGE	
B	1	TF6CURVED	6"	FEMALE NPT	THRD. TANK FLANGE	PRIMARY EMERGENCY VENT
C	1	TF6CURVED	6"	FEMALE NPT	THRD. TANK FLANGE	INTERSTITIAL EMERGENCY VENT
D	1	LIFTLUG2-900SM	SMALL	LIFT LUG	6,800# EACH	

B

B

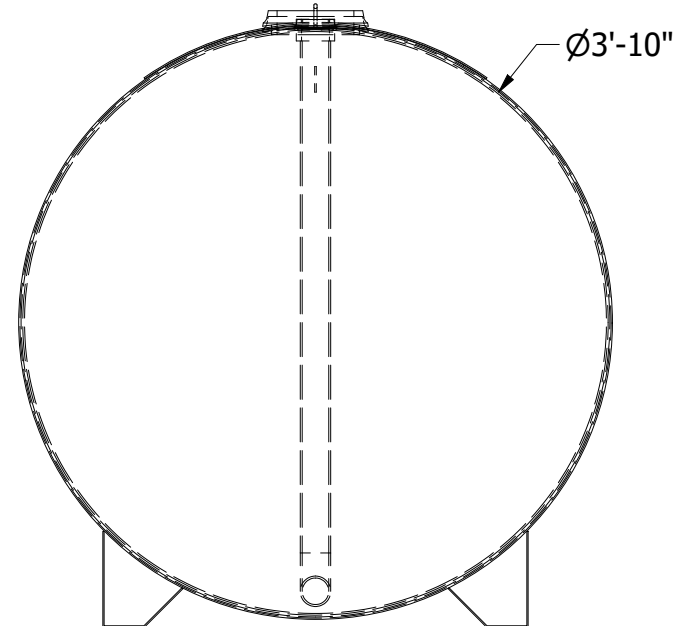

BOX SILLS 4 REQUIRED.
FOUR 6" WELDS EQUAL SPACED PER SILL

Ø2" X 40" PIPE WITH HALF CPL
Ø2" 90° LONG RADIUS WELD ELBOW
2" X 1/4" BAR 6" FROM TOP

- NOTES:
- CLEAN TANK COMPLETELY AFTER WELDING.
 - INSPECT TANK FOR UNDERCUT & CONCAVE WELDS BEFORE SECOND TEST.
 - SECOND TEST TANK AFTER SILLS ARE WELDED.

PRODUCT CODE: DW1000ULSKT46D		DESCRIPTION: 1000 GAL UL-142 DOUBLE WALL SKID TANK			STEEL TANK & FABRICATING CORP.		
FOR: STOCK		CUSTOMER APPROVAL:		QUANTITY: 6	CAPACITY: 1000 GAL	APP. WEIGHT: 1698 lbmass	COLUMBIA CITY, IN 46725 800-852-9102 / 260-248-8971 / FAX 260-248-8973
		<input type="checkbox"/> MAKE NOTED CHANGES AND RE-SUBMIT <input type="checkbox"/> APPROVED WITH CHANGES NOTED <input type="checkbox"/> APPROVED AS DRAWN		DIAMETER: 46"	LENGTH: 12'	LABEL: UL-142	
PAINT: BLAST / ENAMEL WHITE		SIGNATURE: _____		MATERIAL: MCS	HEADS: 10GA 12GA	SHELL: 10GA 12GA	DRAWN BY: KRM
				CUSTOMER ORDER#: -	STAFCO ORDER#: STOCK	SCALE: 1 / 15	CHECKED BY: GFS
							DATE: 9/11/2023
							SHEET: 1 OF 1



4

3

2

1

A

A